



HAZARDOUS LOCATION INTERCOM STATION

- **Corrosion and vandal resistant design**
- **Private full duplex handset communication**
- **Headset, gooseneck microphone and handset options**
- **Single touch speed dialing**
- **Group call, all-call, priority call, auto conference**
- **Simple one pair wiring**
- **Output to powered loudspeaker**
- **IP66**

ECHO EZ1 SERIES

Zone 1 Digital Intercom Stations

Federal Signal Model EZ1 ECHO Intercom Stations provide safe and efficient two-way voice communications in large and small ECHO Digital Intercom Systems. The EZ1 ECHO Station is designed and approved for use in Zone 1 Hazardous Areas, Ex II 2 G EEx meib IIC T6.

The EZ1 ECHO ATEX station provides instantaneous high-speed connections and clear, crisp digital voice quality. Each station offers single-button all call, priority emergency paging, group paging, speed dial, conference call, and relay output.

Any station can call any other station(s) in an ECHO Digital Intercom System. With the headset or gooseneck microphone options, each is capable of hands-free voice communication. Because the ECHO Digital Central Exchange provides 30 channels of simultaneous communication, calls are processed and connected immediately without dial tone or delay.

The EZ1 Station keypad is designed to provide tactile and audible feedback (via external powered loudspeaker) for a positive activation. Each station may be programmed for four levels of privacy for receiving calls; non-private, semi-private, full privacy and do-not-disturb. Volume for voice and signal levels are easily adjusted on the keypad.

Each EZ1 Station is constructed of heavy duty glass reinforced polyester (GRP), equipped with a weatherproof keypad, and are rated for use in IP66 dust- and water-tight applications.



SPECIFICATIONS

Operating Voltage:	24VDC nominal (line driven from ECHO control)
Current Idle:	25mA
Current Connected:	100mA
Handset Microphone Type:	Dynamic
Handset Material:	Moulded Polyurethane
Handset Cord:	Stainless Steel
Stubby Microphone Type:	Dynamic
Stubby Microphone Sensitivity:	-54dB
Stubby Microphone Enclosure:	Stainless Steel
Audio Output:	2.7VRMS / 1.0k ohm load
Volume Control via Keypad:	30dB in ten steps
Line Attenuation:	24dB@160kb/s Max
Loop Resistance:	170 Ohm Max
Distance:	2.0km (1.2 miles) Max
Cable:	One twisted pair, non-shielded
Cable Entries (bottom):	3 x M20
Operating Temperature Range:	-35C to +50C (T6)
Termination:	EEx e screw terminal block
Relay Switching Capacity:	3A at 240VAC
Net Weight:	4.3kg (9.5 lbs)
Shipping Weight:	5.1kg (11.1 lbs)
Shipping Dimensions:	413mm x 241mm x 235mm (16.25" x 9.5" x 9.25")
Certificate Number:	BAS01ATEX2306X
Classification Marking:	Ex II 2 G EEx meib IIC T6
Ingress Protection:	IP66 (IP65 on handset)

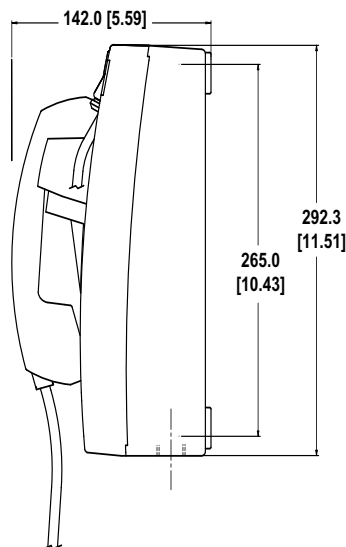
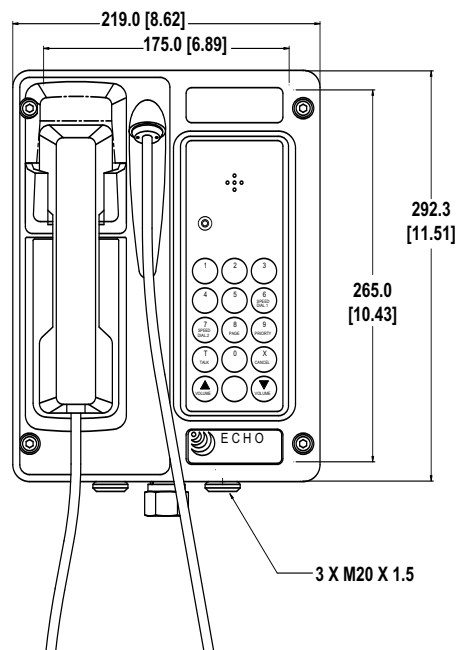

MODELS AVAILABLE

EZ1-HND-C	Handset, 1.8m curly cord
EZ1-HND-S	Handset, 1.0m stainless steel cord
EZ1-JS	Jack station
EZ1-SM	Stubby microphone, 65mm
EZ1-GM1	Gooseneck microphone, 260mm
EZ1-GM2	Gooseneck microphone, 440mm
EZ1-GM3	Gooseneck microphone, 590mm
K8601241A	Potted relay assembly, EZ1

JACK STATION OPTIONS

K137149A-01	Headset
K1751234A	10m Headset extension cord
K8601272A-01	Handset with 10m curly cord (detachable)

